

IMMERSION SLEEVES FOR 6 AND 5,5MM SENSORS

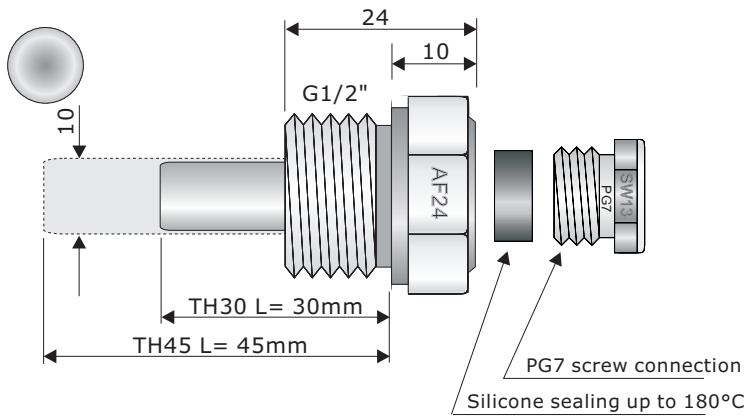

ITEM ... 09030

Type: TH30MS nickel-plated
Temperature range: up to +150°C

For mounting in pipe T- piece from 22mm immersion Pipe MS
Immersion depth incl. thread: L= 30mm
Pipe thread G-1/2" AF24 consisting of MS58 with PG7 cable connection and silicone sealing.

Applicable with sensor ITEM ... TT5.5

ITEM ... 09045

Type: TH45MS nickel-plated
Immersion depth: 45mm

Applicable with the sensor ITEM ... Tt6

IMMERSION SLEEVE FOR 6 AND 5,5MM SENSORS

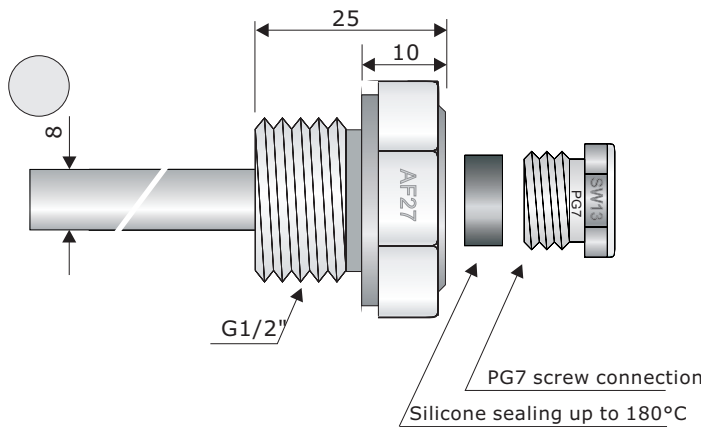

ITEM ... 9027 - SW27

ITEM ... 9021 - SW21

Type: TH60MC ; TH100MC ; TH150MC ; TH200MC
Temperature range: up to +150°C

Immersion pipe (Cu): L= 60 ; 100 ; 150 ; 200mm
Pipe thread G-1/2" AF21 or AF27 consisting of MS58 with PG7 cable connection and silicone sealing.

Applicable with the sensor ITEM ... TT5.5 / TT6

ITEM ... 9027E - SW27

ITEM ... 9021E - SW21

Type: TH60E ; TH100E ; TH150E ; TH200E
Temperature range: up to +400°C

Immersion pipe: L= 60 ; 100 ; 150 ; 200mm
Material: Stainless steel 1.4571 or 1.4404

PG7 screw connection with silicone sealing up to +180°C

Applicable with the Sensor ITEM ... TT5.5 / TT6

(E-polished for applications in the laboratory and food technology.)

IMMERSION SLEEVES FOR 4MM SENSORS

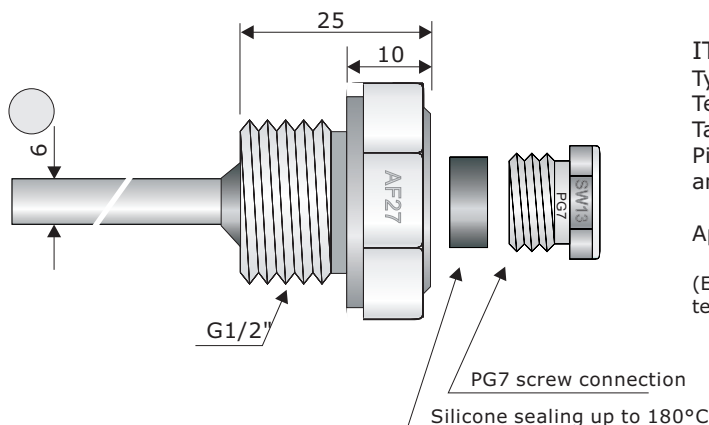

ITEM ... 9004E

Type: TH30E ; TH45E ; TH60E ; TH150E ; TH200E
Temperature range: measuring tube up to +400°C

Tauchrohr: L = 60 ; 100 ; 150 ; 200mm
Pipe thread G-1/2" AF27 with PG7 cable connection and silicone sealing up to +180°C

Applicable with the sensor ITEM ... TT4

(E-polished for applications in the laboratory and food technology.)